

NOT A RECOMMENDED HECO CONFIGURATION

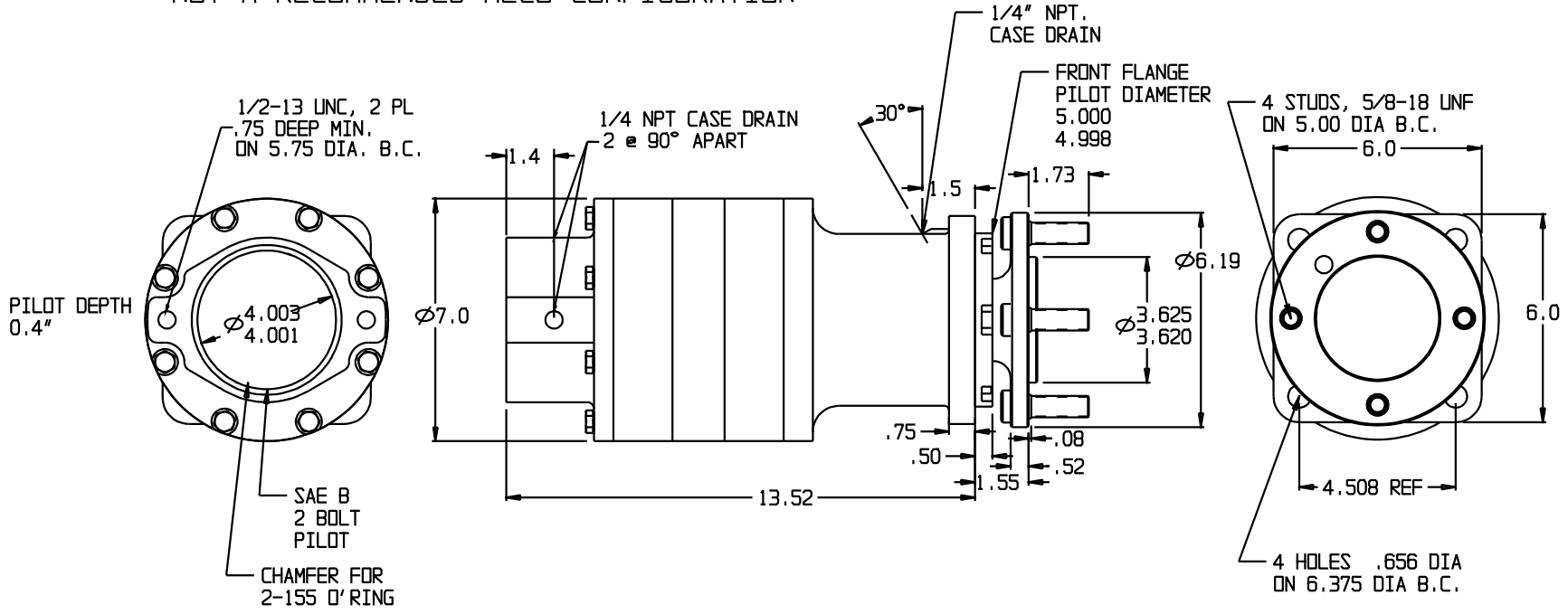

SUN GEARS- SUGGESTED MOTOR SHAFT LENGTHS

| SUN GEAR | SHAFT TYPE | MIN. (IN.) | MAX. (IN.) |
|----------|----------------------|------------|------------|
| 16B | 7/8" 13T SPLINE | 1.40 | 1.75 |
| 16C | 1" 15T SPLINE | 1.70 | 1.95 |
| 16D | 1" ST. KEYED | 1.80 | 2.10 |
| 16E | C/L 2000 BEARINGLESS | N/A | N/A |
| 16F | C/L 4000 BEARINGLESS | N/A | N/A |
| 16H | 1 1/4" ST. KEYED | 2.05 | 2.40 |
| 16I | 1 1/4" 14T SPLINE | 2.00 | 2.32 |
| 16M | 1" SAE 6B SPLINE | 1.95 | 2.30 |

©COPYRIGHT 2001, HECO GEAR, INC.

| REV | DESCRIPTION | DATE | APPROVED |
|-----|-------------|------|----------|
| | | | |
| | | | |
| | | | |
| | | | |

THIS DRAWING CONTAINS PROPRIETARY AND CONFIDENTIAL INFORMATION OF HECO GEAR, INC. IN ACCEPTING THIS DRAWING, (CUSTOMER) ACKNOWLEDGES THE VALUE OF THE INTELLECTUAL PROPERTY CONTAINED HEREIN AND AGREES THAT THE INFORMATION IN THIS DRAWING IS THE PROPERTY OF AND PROPRIETARY TO HECO GEAR, INC. AND MAY NOT BE REPRODUCED WITHOUT THE EXPRESS WRITTEN PERMISSION OF HECO GEAR, INC. ALL RIGHTS RESERVED.



TITLE
MODEL 16 ASSEMBLY
DESCRIPTION
HECO 16 MODEL CODE:
16DFF22527

SIZE: DRAWN BY: KSC DES. NO. _____ REV _____
SCALE: TO NOT SCALE DATE: 04/28/01 SHEET 1 OF 1