

* RATIO DOES NOT CHANGE INSTALLATION DIMENSIONS

WWW.HECOGEAR.COM

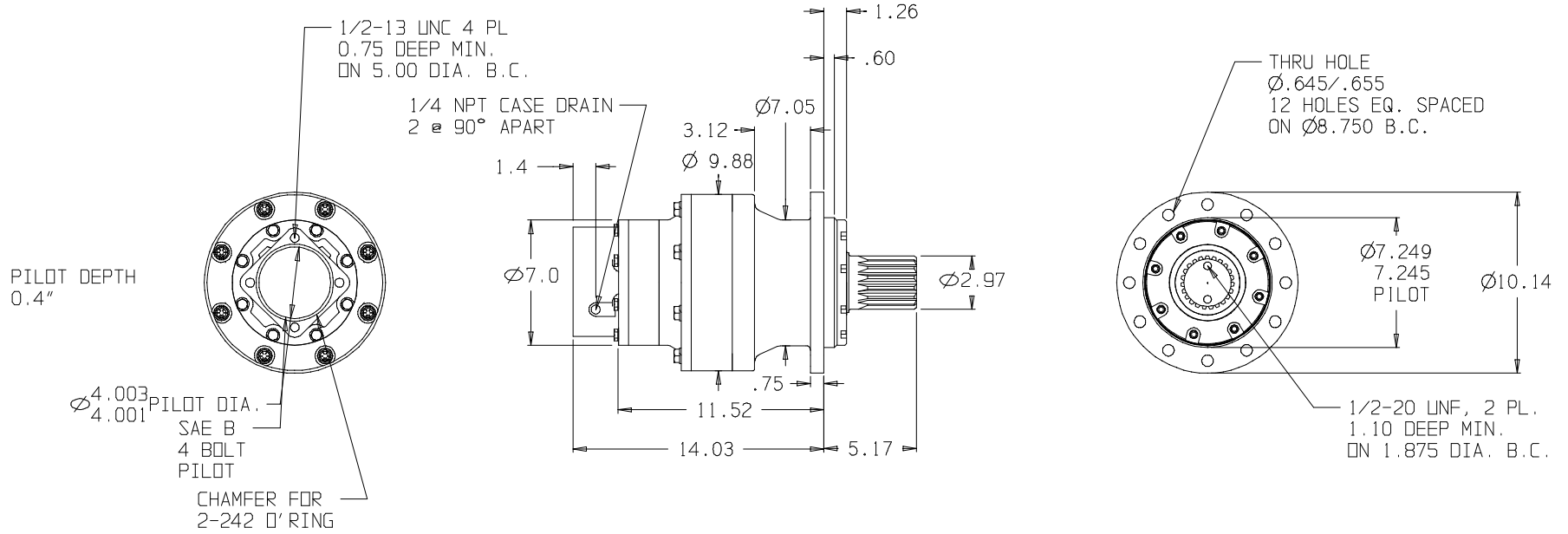

SPLINE DATA

| | |
|---------------------|---|
| NO. TEETH | 23 |
| PITCH | 8/16 |
| P. D. | 2.875 $\text{Ⓜ} \text{A} .002$ |
| PRESSURE ANGLE | 30° |
| TOOTH THKNS | MAX. EFF. .1947 (4.945) MAX. ACT. .1927 (4.895) MIN. ACT. .1913 (4.860) |
| PIN DIA. | .2400 (6.10) |
| MEAS. OVER TWO PINS | 3.2340 (82.144) 3.2318 (82.09) |
| TYPE OF FIT | FLAT ROOT SIDE FIT |
| MINOR DIA. | 2.650 (67.31) 2.632 (66.85) |
| TIF DIA. | 2.7442 (69.703) |

©COPYRIGHT 2002, HECO GEAR, INC.

| SUN GEARS- SUGGESTED MOTOR SHAFT LENGTHS | | | |
|--|----------------------|------------|------------|
| SUN GEAR | SHAFT TYPE | MIN. (IN.) | MAX. (IN.) |
| 16B | 7/8" 13T SPLINE | 1.40 | 1.75 |
| 16C | 1" 15T SPLINE | 1.70 | 1.95 |
| 16D | 1" ST. KEYED | 1.80 | 2.10 |
| 16E | C/L 2000 BEARINGLESS | N/A | N/A |
| 16F | C/L 4000 BEARINGLESS | N/A | N/A |
| 16H | 1 1/4" ST. KEYED | 2.05 | 2.40 |
| 16I | 1 1/4" 14T SPLINE | 2.00 | 2.32 |
| 16M | 1" SAE 6B SPLINE | 1.95 | 2.30 |

THIS DRAWING CONTAINS PROPRIETARY AND CONFIDENTIAL INFORMATION OF HECO GEAR, INC. IN ACCEPTING THIS DRAWING, (CUSTOMER) ACKNOWLEDGES THE VALUE OF THE INTELLECTUAL PROPERTY CONTAINED HEREIN AND AGREES THAT THE INFORMATION IN THIS DRAWING IS THE PROPERTY OF AND PROPRIETARY TO HECO GEAR, INC. AND MAY NOT BE REPRODUCED WITHOUT THE EXPRESS WRITTEN PERMISSION OF HECO GEAR, INC. ALL RIGHTS RESERVED.



2350 DEL MONTE STREET
WEST SACRAMENTO, CA 95601
(916)-392-5411 FAX (916)-393-0352

| | |
|-------------|--|
| TITLE | MODEL 20 ASSEMBLY |
| DESCRIPTION | HECO 20 MODEL CODE: 25DAF4 0 31* |
| SIZE | DRAWN BY: KSC |
| SCALE: | DO NOT SCALE |
| DWG NO. | 001012R |
| DATE: | 04/19/01 |
| SHEET | 1 OF 1 |