

# Model 16

## *Parts and Lubrication Information*

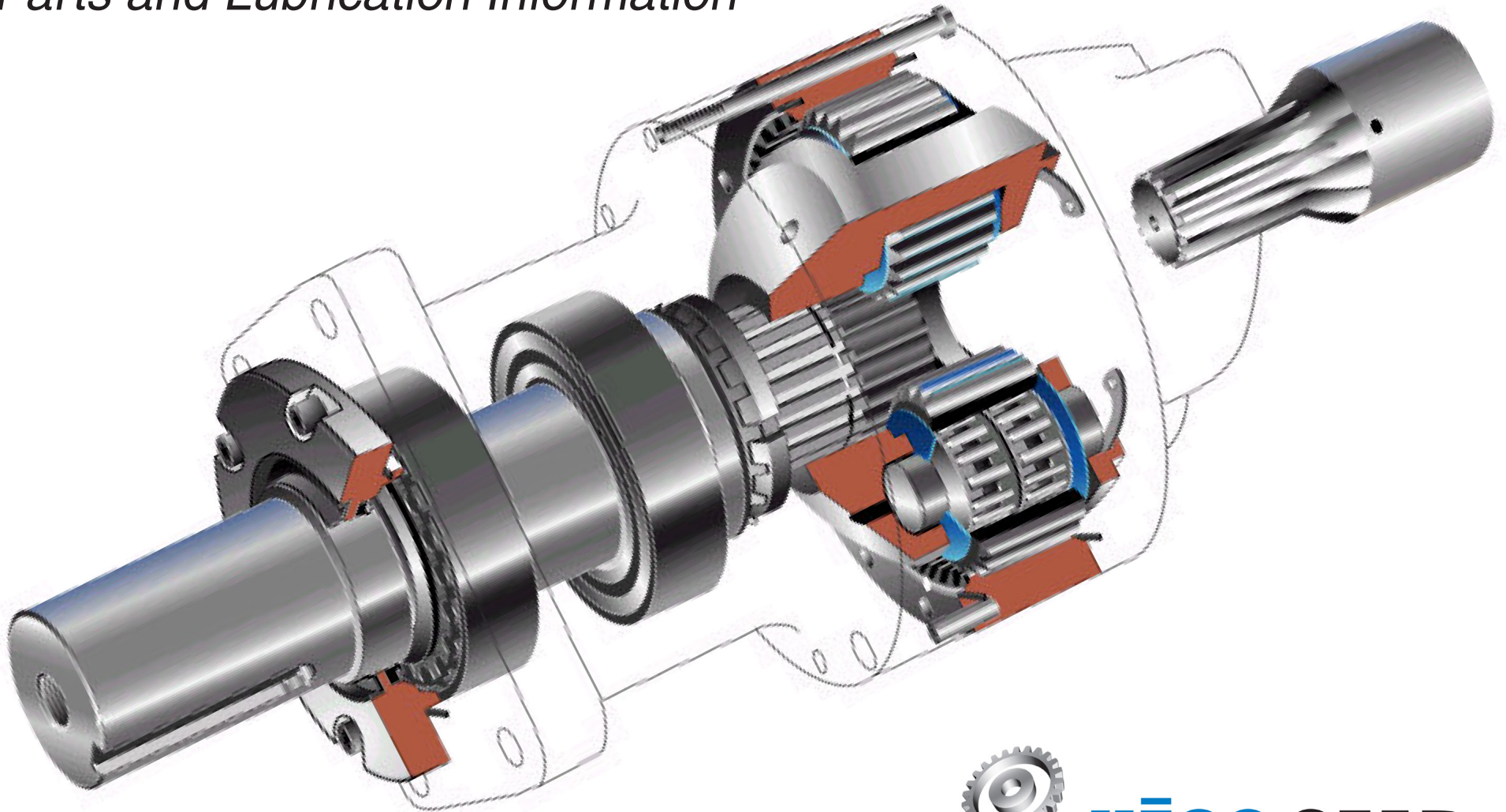

Model 16 Performance Specifications: [www.hecogear.com/m16performance.pdf](http://www.hecogear.com/m16performance.pdf)

Heco Terms and Conditions of Sale: [www.hecogear.com/termsandconditions.pdf](http://www.hecogear.com/termsandconditions.pdf)

Heco Warranty: [www.hecogear.com/warranty.pdf](http://www.hecogear.com/warranty.pdf)



**HĒCO GEAR**  
Planetary Speed Reducers for Industry

ITEM #	PART #	DESCRIPTION	QTY/ASSY
1.	151110	<b>Seal Carrier Bolts</b> Socket Head - Black Oxide	5
	151170	Socket Head - Stainless Steel	5
2.	156200	<b>Shaft Seals</b> Standard Seal - Buna	2
	156210	Optional Seal - Viton	2
3.	15916A	<b>Seal Carrier</b> Standard Carrier	1
	15917A	Optional Carrier - Nickel Plated	1
4.	151330	<b>Seal Carrier O-Ring</b> O-Ring - Buna	1
	151335	O-Ring - Viton	1
5.	15053E	<b>Output Shaft</b> 2.250" Straight Keyed	1
	15073E	2.250" Straight Keyed - Plated	1
	15057C	4 Bolt Flanged - 1/2" Studs	1
	150772	4 Bolt Flanged - 5/8" Studs Plated	1
	15058A	4 Bolt Flanged - 5/8" Studs	1
	150540	2.250" J501 Tapered	1
	15099D	16 Tooth - 8/16DP Splined	1
	15224C	5 Bolt Flanged - 1/2" Studs	1
	15223A	5 Bolt Flanged - 5/8" Studs	1
	15060C	2.000" Straight Keyed	1
	15230A	2.545 Round w/ Cross Hole	1
	15231A	2.000" Hex w/ Cross Hole	1
	15912A	1.625" Square Shaft	1
	152290	10 Bolt Flanged - 5/8" Studs	1
6.	150152	Thrust Plug	1
7.	15958A	Tapered Roller Bearing Set	2
8.	151290	Pipe Plug	4
9.	15952A	<b>Bearing Housing</b> Front Flange	1
	15955A	Center Flange	1
	15951A	"A" Flange	1
10.	150120	<b>Housing O-Ring</b> O-Ring - Buna	2
	150125	O-Ring - Viton	2
11.	151630	Keyed Thrust Washer	1
12.	151620	Tanged Lock Washer	1
13.	151380	Lock Nut	1

ITEM #	PART #	DESCRIPTION	QTY/ASSY
14.	160007	<b>Planet Carrier</b> 5.2:1 Planet Carrier Assembly	1
15.	157110	Planet Carrier Housing	1
16.	157120	Planet Pin	3
17.	157190	Thrust Washer	6
18.	157180	Planet Bearing	6
19.	157130	Planet Gear	3
20.	156140	Retaining Ring	1
21.	150110	Retaining Ring - Wirelock	1
22.	15003I	Ring Gear	1
23.	15175A	Spring Pin	1
24.	15205E	<b>Input Adapter</b> SAE A 2&4 Bolt	1
	15064E	SAE B 2 Bolt	1
	15018E	SAE B 4 Bolt	1
	15209G	SAE C 2&4 Bolt	1
25.	150190	Metric O-Ring Plug	1
26.	151100	Hex Head Capscrew	8
27.	16B	<b>Input Sun Gear</b> 7/8" - 13 Tooth Splined	1
	16C	1" - 15 Tooth Splined	1
	16D	1" Straight Keyed	1
	16E	Charlynn 2000 Bearingless	1
	16F	Charlynn 4000 Bearingless	1
	16H	1-1/4" Straight Keyed	1
	16I	1-1/4" - 14 Tooth Splined	1
	16M	1" SAE 6B Splined	1
	16O	7/8" Straight Keyed	1
	16P	1-1/8" Straight Keyed	1
	16S	Danfoss OMS Bearinless	1

Model Number Shown:  
**16CF1-05-8 w/16E**

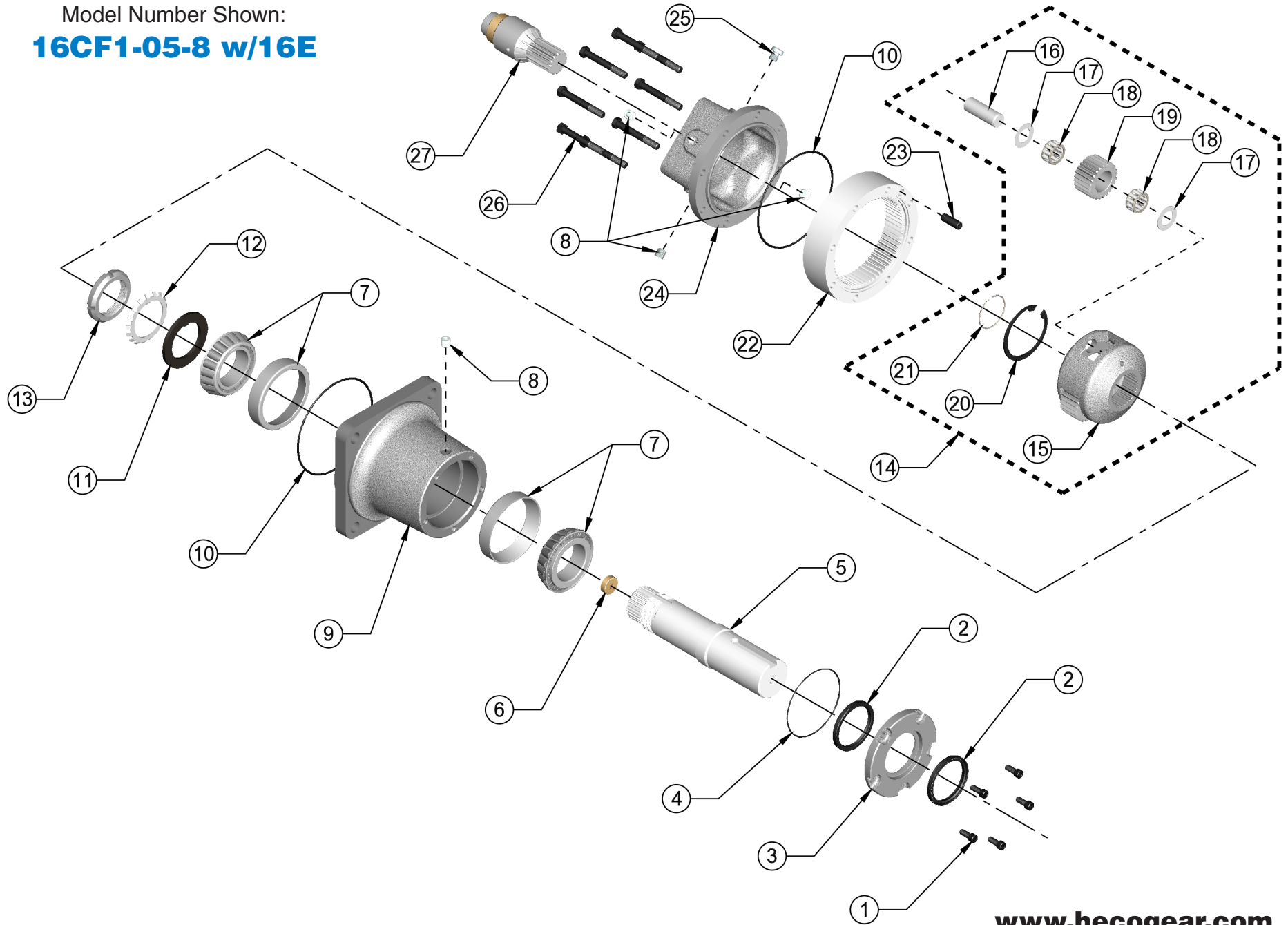

# LUBRICATION INSTRUCTIONS

The Heco Gear Model 16 planetary speed reducer may be lubricated using one of two methods.

## 1. Self-Contained Lubrication

This method is to be used with sealed motors. When using self-contained lubrication you need to install the proper amount of lubrication fluid into the speed reducer. The amount of fluid depends on the mounting orientation of the speed reducer.

### Mounting Orientations

*Shaft Horizontal* - The speed reducer should be filled 1/2 full.

*Vertically Shaft Down* - With the shaft facing down, fill the speed reducer to the centerline of the upper gear set prior to installing the motor.

*Vertically Shaft Up* - The speed reducer must be completely filled and provisions made for maintaining the fluid level at or above the top shaft bearing. This can be done using a “stand pipe” or small reservoir

### Model 16 Oil Capacity

Horizontally Mounted (1/2 Full):

20 Oz.    0.63 Qt.    0.59 L

Vertically Mounted (Full):

40 Oz.    1.25 Qt.    1.18 L

### Recommended Lubricant

*Maximum Life* - For maximum speed reducer life the recommended oil is SAE 85W-140 Multi-Grade gear oil meeting API-GL5 and API-MT1 service.

*Adequate Life* - If 85W-140 gear oil as specified above is unavailable, 90W gear oil meeting API-GL5 and API-MT1 service, may be substituted.

These lubricants should be available at your local automotive stores or Heco distributor.

### Breathers/Case Vent

No breather is required or recommended when using self contained lubrication. The seals in the Heco speed reducer are designed to retain case pressure caused by thermal expansion up to 50 PSI.

The use of a breather may introduce contamination to the lubricating oil from the external environment.

### 2. Flow-Through Lubrication

In this method of lubrication, fluid from the hydraulic system is used to lubricate the speed reducer. This is most commonly done with a “bearingless” hydraulic motor which has no shaft seal and the internal leakage of the motor flows into and lubricates the speed reducer. A petroleum based hydraulic fluid with EP1 additives and a minimum of 0.125% zinc anti-wear additive should be used to ensure good speed reducer life at rated torques and speeds.

If you are using either of the below sun gears you **MUST** use flow-through lubrication:

*16E - Charlynn 2000 Bearingless*

*16F - Charlynn 4000 Bearingless*

Notes:

1. The speed reducer should be completely filled with hydraulic fluid **BEFORE** the hydraulic motor is installed and/or the unit is ran. Do not rely on the motor drain to fill the speed reducer!

2. **Case Drains** - No case drain is required provided the return line pressure of the hydraulic motor does **NOT** exceed 50 PSI. If the return line pressure is higher than 50 PSI (such as if the motor is being used in series or if you are using a meter out flow control) then make sure to attach the drain line to the case of the motor or the port on the speed reducer in the highest position. Which location to use depends on the flow path of the motor

Case drains for the 16E & 16F sun gears should be configured as follows:

*Charlynn 2000 Bearingless* - Connect drain line to the case of the hydraulic motor

*Charlynn 4000 Bearingless* - Connect drain line to the port on the speed reducer in the highest position.

If the above guidelines are not followed damage to the speed reducer internal parts may occur.

### Seal Kits

Listed below are the available seal kits for the model 16. Soft parts kits contain all O-rings and seals listed in the parts breakdown. Universal kits contain all O-rings and an assembled seal carrier & hardware.

#### Current Revision Kits

SK16-8	Soft Parts Kit - Buna
SK16-8V	Soft Parts Kit - Viton
SK16-8U	Universal Kit - Buna
SK16-8N	Universal Kit Nickel - Buna

#### Obsolete Unit Kits

SK16-7	Soft Parts Kit - Buna
SK16-U	Universal Kit - Buna
SK16-4	Quad Soft Parts Kit - Buna
SK16-QU	Universal Kit Quad - Buna

\*more seal kit options available - see price list

### Maximum Oil Temperature

Continuous - 160° F (70° C)

Intermittent - 180° F (82° C)

### Periodic Maintenance

Reducers using the standard self-contained lubrication should have the fluid drained after the first 50 hours of operation. The reducer should then be flushed with oil, and re-filled with the recommended lubricant. The oil should be changed approximately every 1,000 hours of use. Reducers using flow through lubrication require no maintenance.