

**Model: 16 & 16D**

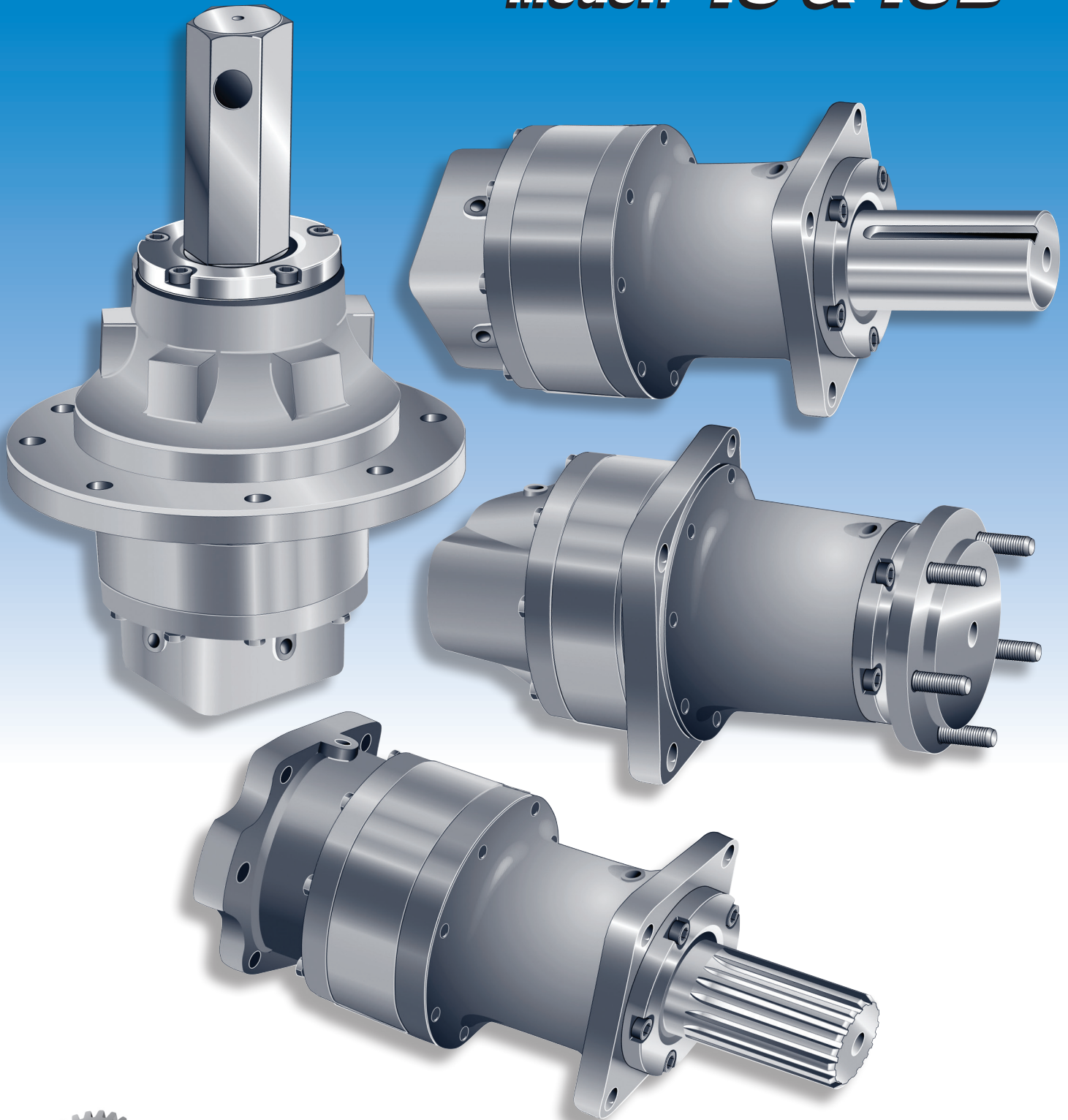

**HECO GEAR**  
Planetary Speed Reducers for Industry

P.O. Box 1388  
West Sacramento, CA 95691  
(916) 372-5411  
Fax: (916) 373-0952  
[www.hecogear.com](http://www.hecogear.com)

# Heco Gear Warranty Information

---

1. Heco Inc. (“Heco”), dba HECO GEAR, warrants its Products to be free from defects in material and workmanship for a period of twelve (12) months from the date of first use or eighteen (18) months from the date of manufacture, whichever occurs first.
2. Any Heco Product Buyer claims to be defective must be returned by Buyer to Heco for inspection by Heco factory personnel at Heco’s factory. Buyer’s sole remedy with respect to any defective Product shall be replacement or repair of the part or Product determined to be defective by Heco’s factory inspection, at Heco’s option.
3. Heco Warranty does not apply to any Product that has been disassembled or modified in any way outside of Heco’s factory or to failures due to reasons other than defects such as accidents or misuse.
4. Any alterations or modifications made to the Product (other than those made by Heco) shall render this Warranty null and void. No oral or written information or advice given by Heco, its dealers, distributors, agents or employees will create a warranty or in any way increase the scope of the limited warranty set forth herein, and Buyer may not rely on any such information or advice.

THIS IS THE SOLE AND ONLY WARRANTY OF HECO AND NO OTHER WARRANTY IS APPLICABLE, EITHER EXPRESSED OR IMPLIED, IN FACT OR BY LAW, INCLUDING ANY WARRANTY AS TO MERCHANTABILITY OR FITNESS FOR A PARTICULAR USE OR PURPOSE, WHICH WARRANTIES ARE EXPRESSLY WAIVED BY BUYER.

**Heco Terms and Conditions of Sale:** [www.hecogear.com/termsandconditions.pdf](http://www.hecogear.com/termsandconditions.pdf)

## Application Data Sheet

It is recommended that applications be submitted to Heco Engineering using the Application Data Sheet which can be found at [www.hecogear.com/public/application\\_datasheet.asp](http://www.hecogear.com/public/application_datasheet.asp). Heco Engineers can estimate speed reducer life for your specific application, however, testing the speed reducer in the specific application by the customer will determine actual life.

\*Specifications and dimensions contained in this brochure may be changed at any time. For the most up-to-date information consult the Heco Gear web site at [www.hecogear.com](http://www.hecogear.com).

# Model 16 & 16D Performance Data

**Peak Operating Torque: 30,000 In-Lb, 3,390 N•m**

**Output RPM: Up To 450 RPM Single Reduction, 90 RPM Double Reduction**

**Ratio: 5.2:1 Single Reduction, 27.0:1 Double Reduction**

**Radial Load: Up To 20,000 Lbs**

## Operating Torque Vs. Speed Chart

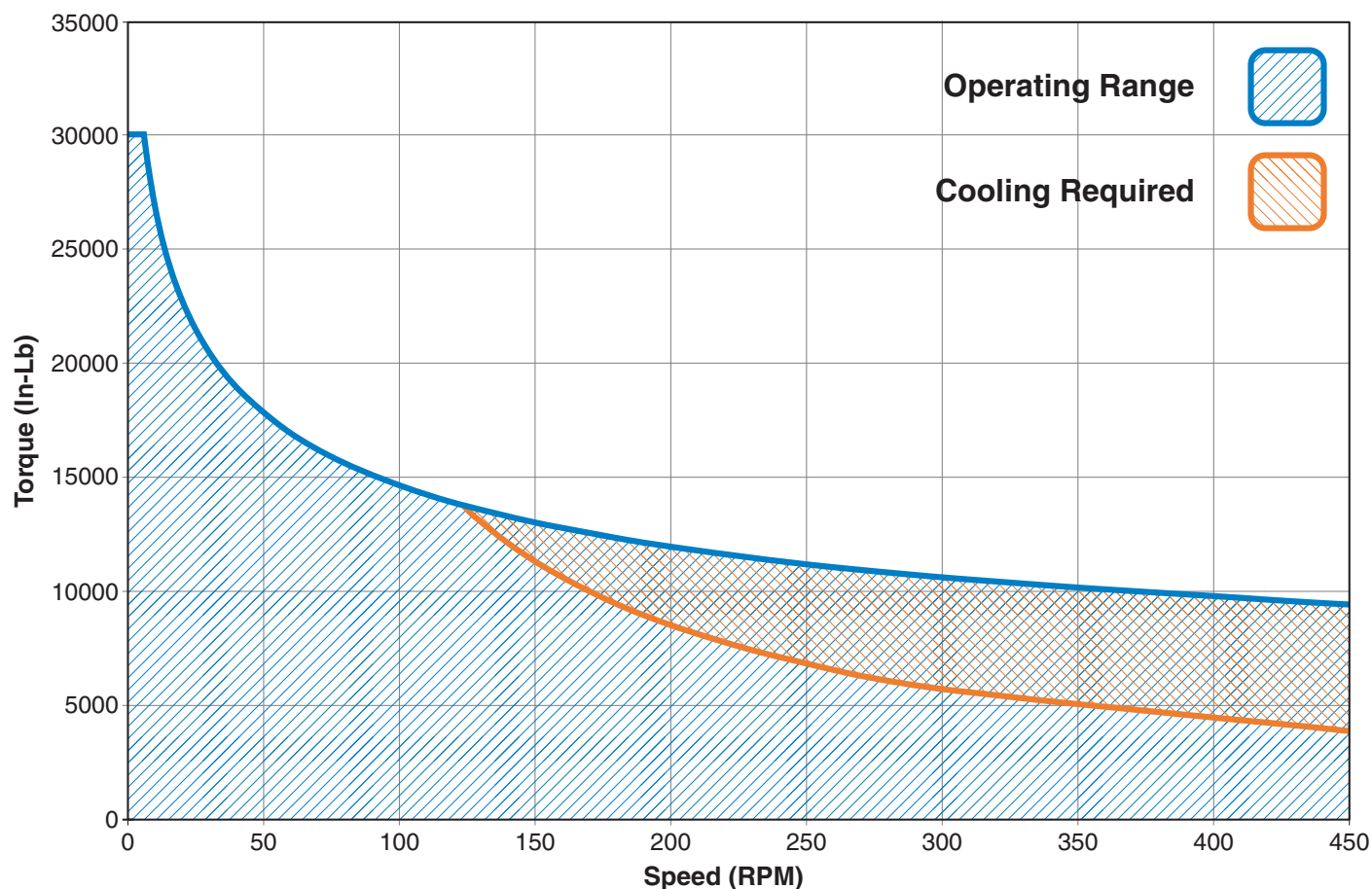

1. The Load vs speed chart above was generated by HECO GEAR testing using AGMA 7S-EP Synthetic gear lubrication and is an indication of the capacity of the HECO Model 16 Speed Reducer.
2. Reducer life is dependent on the duty cycle of the specific customer application and may vary based on the application and proper lubrication. Actual reducer life can only be determined by testing the selected reducer in the specific customer application.
3. Consult Heco Engineering for applications where torques exceed the above torque curve for short durations.
4. Cooling may be required due to the operating horsepower of the application. Cooling can be achieved by adding external cooling or internal by adding an oil cooling loop or through the use of synthetic gear oils with specific heat dissipating properties.
5. When using brakes, it is recommended brakes be applied on the output shaft of the reducer. Dynamic braking on the input of the Heco gear reducer voids the warranty.

# Output Shaft Bearing Radial Load Curve

**Model 16 Output Bearing Life Curve**  
3000 Hours at 100 RPM (L10 Life)  
18,000,000 Revolutions

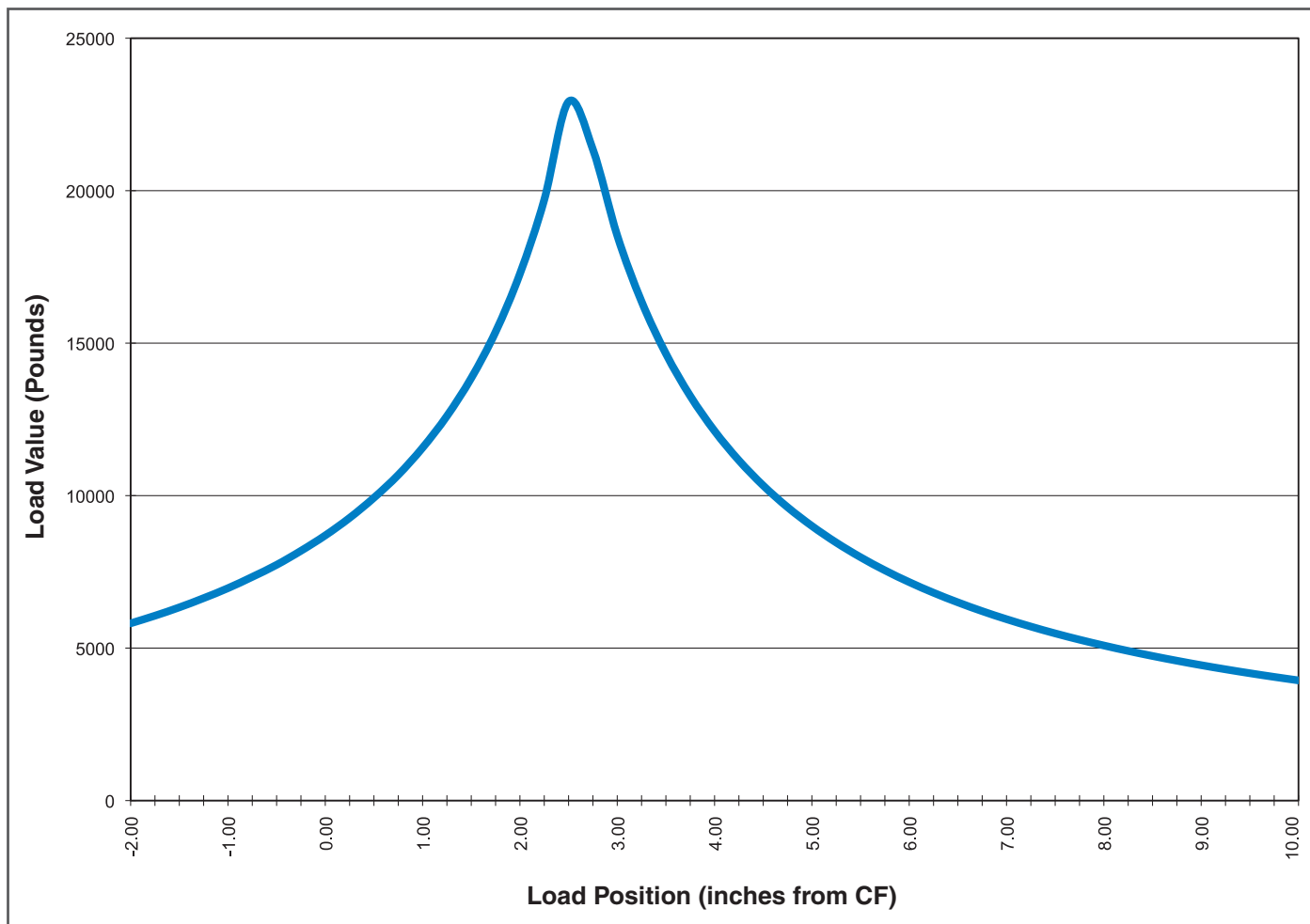

## Oil Recommendations

Oil with EP (Extreme Pressure) additives are crucial to life of a Reducer. ISO VG-460 EP, AGMA 7 EP Gear Lubes are formulated from the most premium base fluids and combined with exclusive additive technology to improve performance and extend speed reducer life.

ISO VG-460 EP, AGMA 7S EP, PAO Synthetic gear oil is the premier gear oil for heavy duty gear drive applications. It is the recommended oil for Heco Reducers and is the oil used when generating Heco Gear performance data. Consult your oil provider for alternate recommendations.

When using a bearingless hydraulic motor or “Flow Through” lubrication, where hydraulic oil flowing from the hydraulic motor lubricates the speed reducer, an ISO 68 hydraulic oil with EP1 additives and a minimum of 0.125% zinc anti-wear additive should provide adequate speed reducer lubrication.

Maximum oil temperature should not exceed 160°F (71°C) for continuous operation or 180°F (82°C) for intermittent operation.

Consult Heco Gear for applications requiring use of non-petroleum based or fire retardant lubrication.

# Model Codes & Ordering Information

MODEL	OUTPUT SHAFT	MOTOR ADAPTER	RATIO	DESIGN NUMBER
<input type="text"/>	<input type="text"/>	<input type="text"/>	<input type="text"/>	<input type="text"/>
<b>16FF</b> – Front Flange (5.2:1)	<b>1</b> – 2.250" Keyed Shaft	<b>0</b> – SAE B; 4 bolt	<b>5</b> – 5.2:1	<b>8</b> – Current design
<b>16CF</b> – Center Flange (5.2:1)	<b>2</b> – 4 Bolt Flange (1/2" studs)	<b>4</b> – SAE A; 2 & 4 bolt	<b>27</b> – 27.04:1	
<b>16AF</b> – "A" Flange (5.2:1) See drawings on page 2	<b>22</b> – 4 Bolt Flange (5/8" studs)	<b>5</b> – SAE B; 2 bolt		
<b>16DFF</b> – Front Flange (27:1)	<b>3</b> – 2.250" J501 Tapered	<b>6</b> – SAE C; 2 & 4 bolt		
<b>16DCF</b> – Center Flange (27:1)	<b>4</b> – 16 Tooth 8/16 Splined	See page 7 for more detail		
<b>16DAF</b> – "A" Flange (27:1) See drawings on page 3	<b>5</b> – 5 Bolt Flange (1/2" studs)			
	<b>52</b> – 5 Bolt Flange (5/8" studs)			
	<b>6</b> – 2.000" Keyed Shaft			
	<b>7</b> – 2.545" Round Shaft			
	<b>8</b> – 2.000" Hex Shaft			
	<b>81</b> – 1.625" Square Shaft			
	<b>9</b> – 9 Bolt Flange (5/8" studs)			
	See page 6 for more detail			

**Sample Model Code: 16DAF1-027-8**

**Sample Sun Gear Code: 16E**

See page 8&9 for more option details

## Common Options:

**Nickel Plating (MIL-C-26074E; Class 2, Grade 0005):** Nickel plated shaft, seal carrier, and stainless steel seal carrier bolts for corrosion prone environments (add A22 suffix to gearbox part number)

**Speed Pickup:** Inductive sensor protected in housing for speed feedback.

**Output Shafts:** Quick turnaround on customized shafts for your application.

**Delivery:** Standard delivery on all Heco gearboxes is 4-6 weeks ARO.

**24 Hour Quick Ship:** Available for all gearboxes and components.

## Approximate Model Weights

Mounting Flange	Single Reduction	Double Reduction
<b>FF</b>	65-67 lbs	90-92 lbs
<b>CF</b>	69-71 lbs	95-97 lbs
<b>AF</b>	87-89 lbs	113-115 lbs

# Model 16 Installation Dimensions

Up To 30,000 in-lbs Torque Output  
5.2 to 1 Ratio

Up To 20,000 lbs Radial Load  
Up To 450 RPM Output Speed

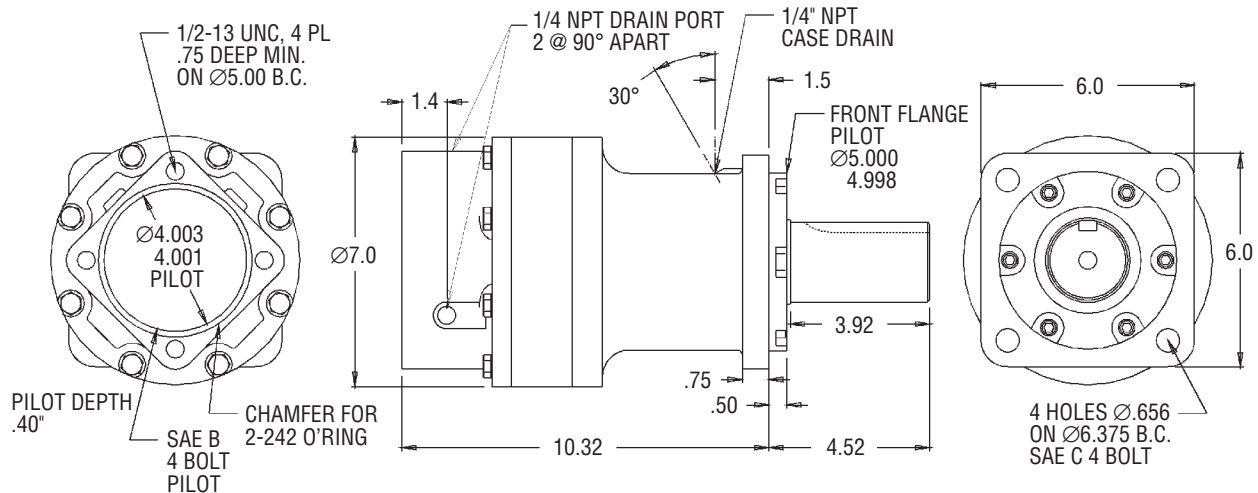

**Model 16FF-1-0-5** Illustrated with Code 1 2.250" Keyed Output Shaft and Code 0 SAE B, 4 Bolt Motor Adapter

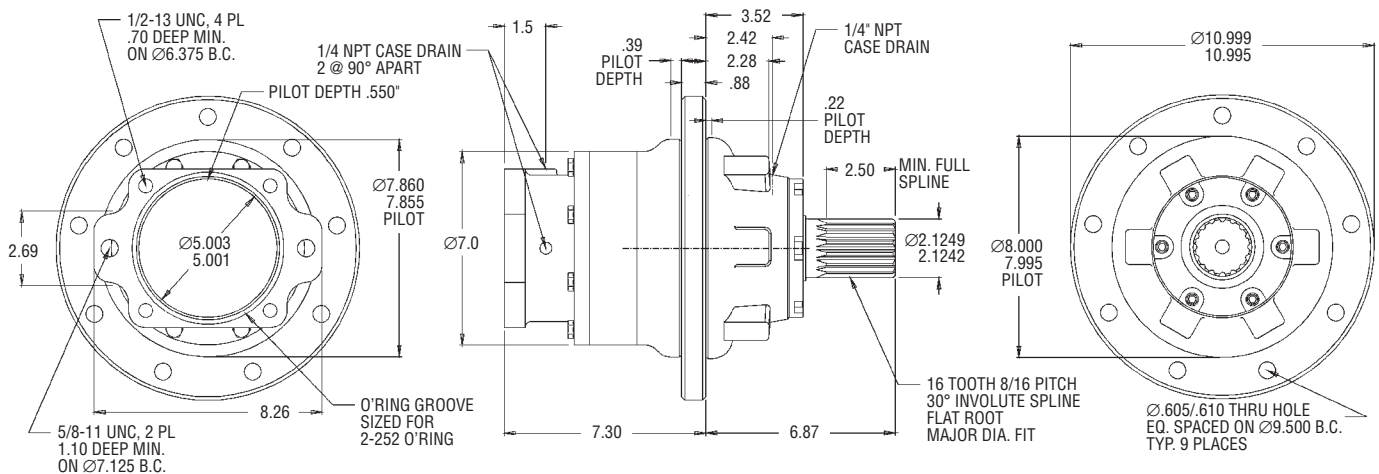

**Model 16AF-4-6-5** Illustrated with Code 4 Splined Output Shaft and Code 6 SAE C, 2 & 4 Bolt Motor Adapter

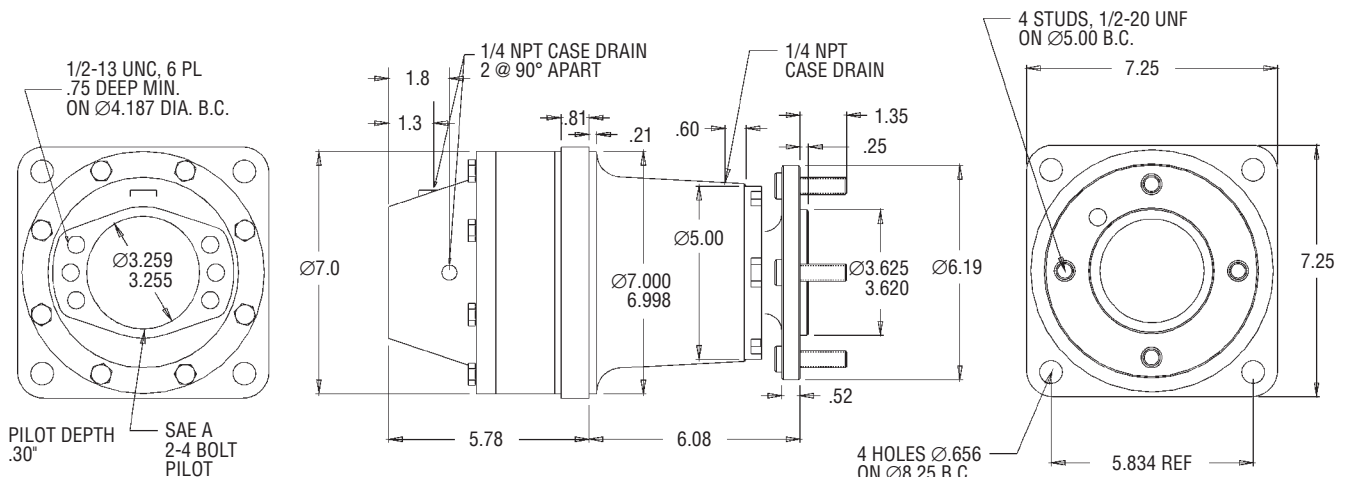

**Model 16CF-2-4-5** Illustrated with Code 2 Flanged Output Shaft and Code 4 SAE A, 2 & 4 Bolt Motor Adapter



# Model 16D Installation Dimensions

Up To 30,000 in-lbs Torque Output  
27 to 1 Ratio

Up To 20,000 lb. Maximum Radial Load  
Up To 90 RPM Maximum Output Speed

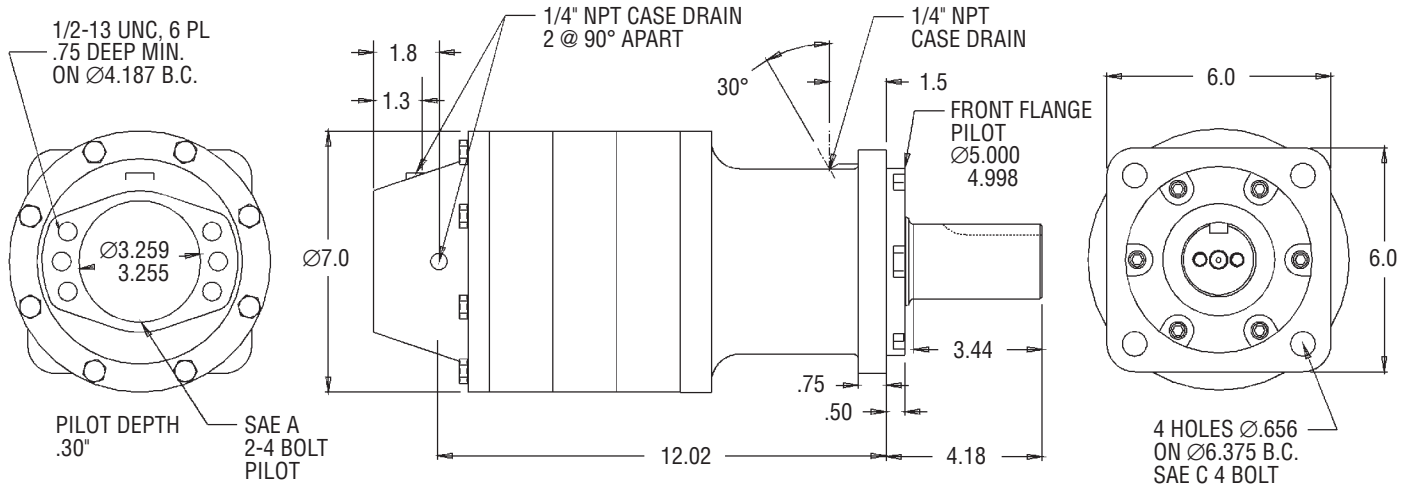

Model 16DFF-6-4-27 Illustrated with Code 6 Keyed Output Shaft and Code 4 SAE A, 2 & 4 Bolt Motor Adapter

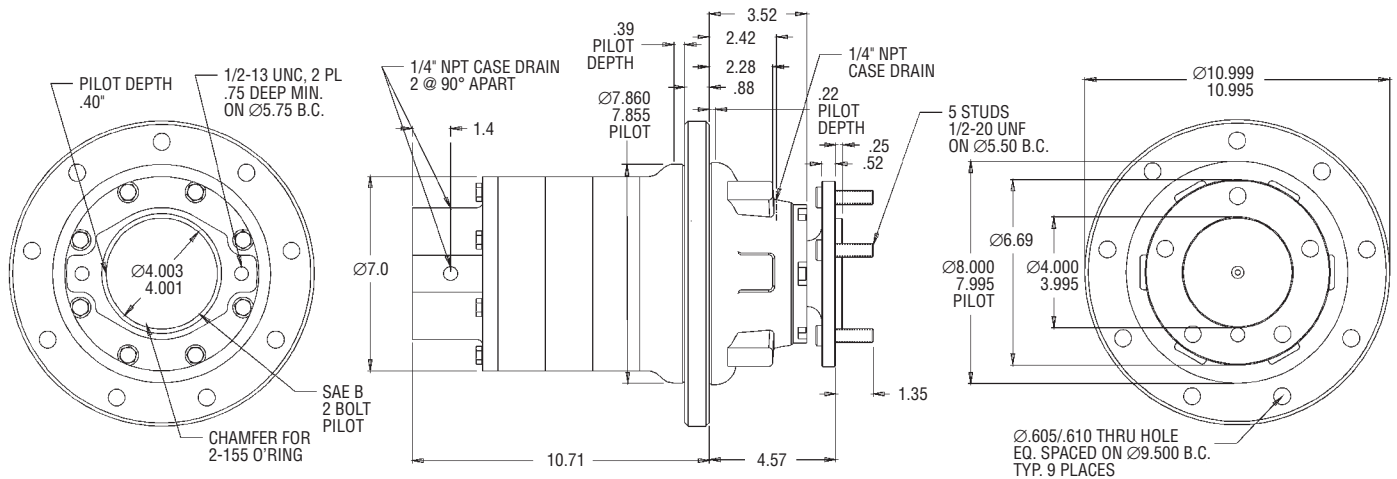

Model 16DAF-5-5-27 Illustrated with Code 5 Flanged Output Shaft and Code 5 SAE B, 2 Bolt Motor Adapter

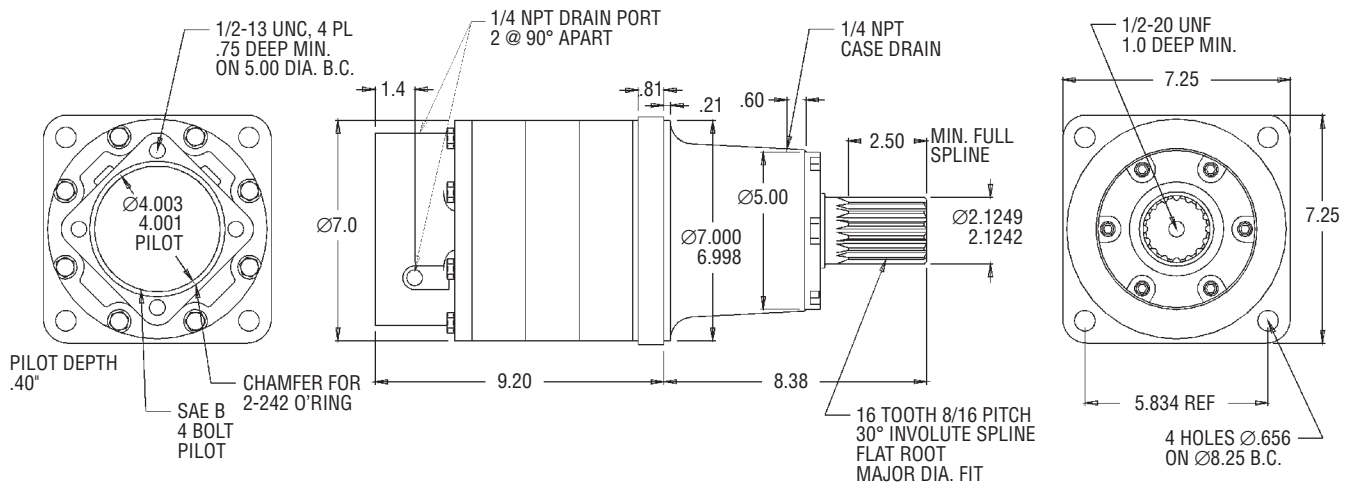

Model 16DCF-4-0-27 Illustrated with Code 4 Splined Output Shaft and Code 0 SAE B, 4 Bolt Motor Adapter

# Output Shaft Options

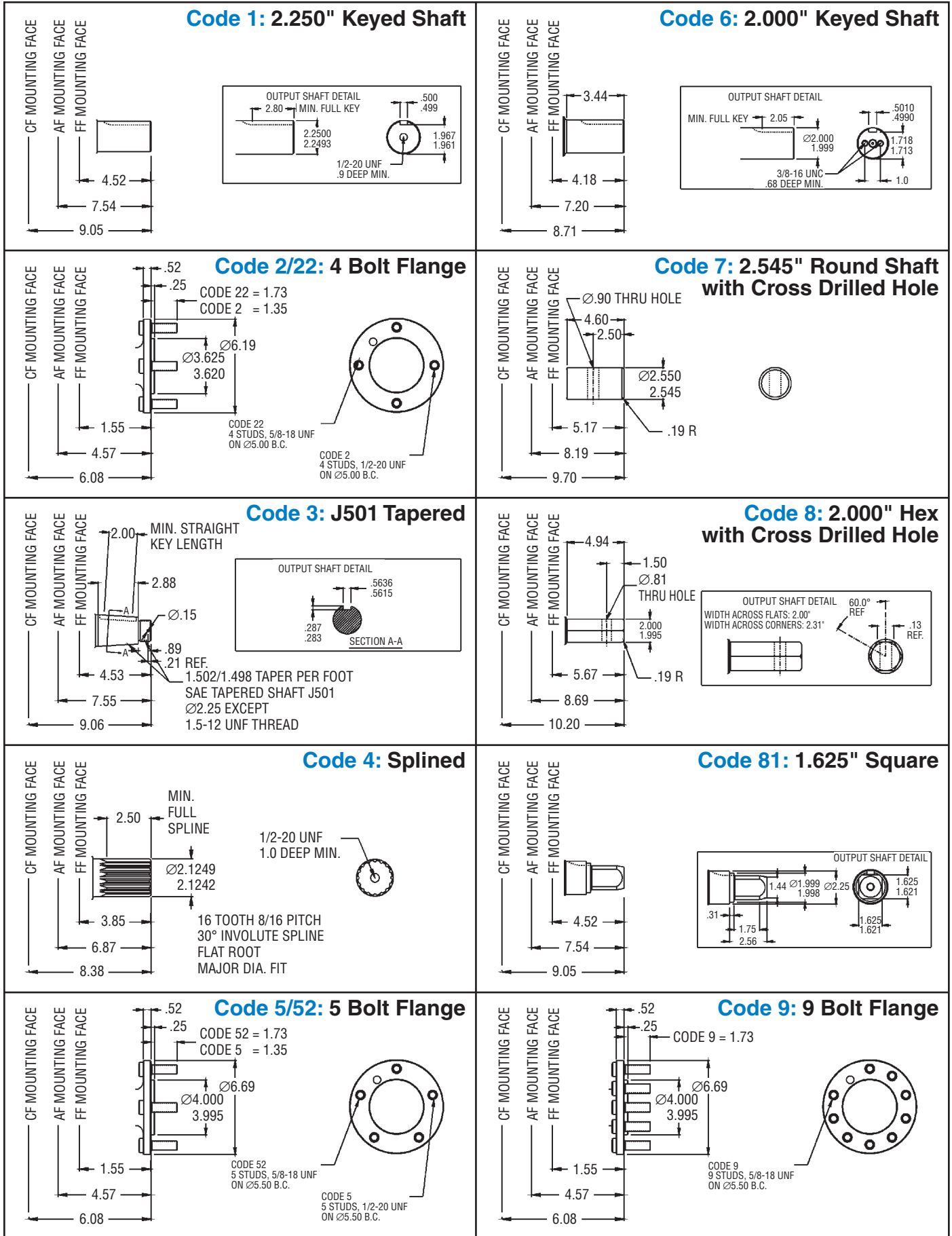



# Hydraulic Motor Adapter Options

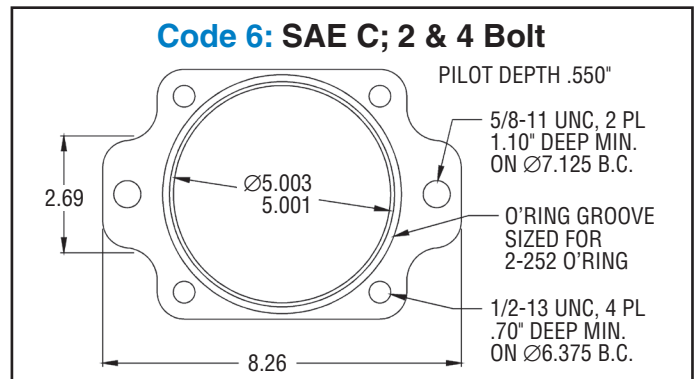
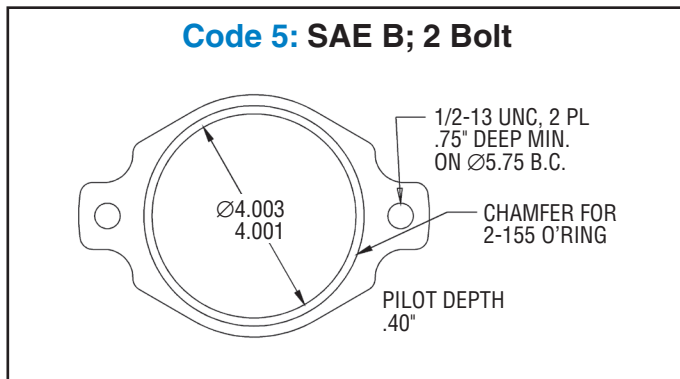
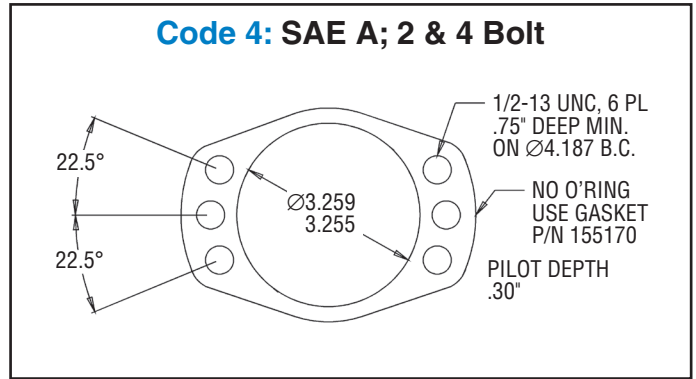
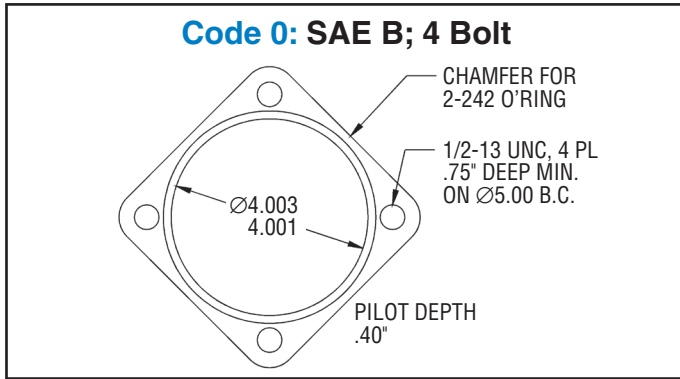

Heco gearboxes ship with all bolts, split washers, gasket/O-ring, necessary to connect your motor.

# Input Shaft / Sun Gear Options

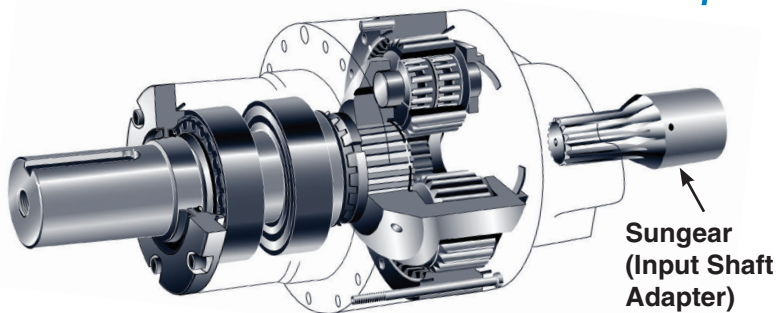

Hydraulic Motor Shaft Length\*

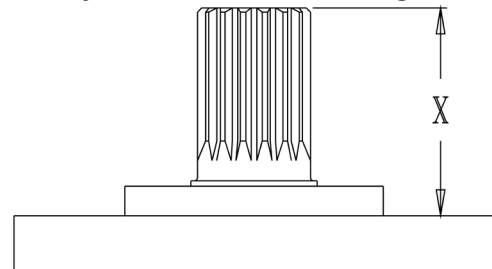

Part #	Hydraulic Motor Shaft Type	Minimum Length - in (mm)*	Maximum Length - in (mm)*
16E	Charlynn 2000 Bearingless	N/A	N/A
16F	Charlynn 4000 Bearingless	N/A	N/A
16S	Danfoss OMSS Bearingless	N/A	N/A
16O	7/8" Straight Keyed	1.80" (45.72)	2.09" (53.09)
16B	7/8" 13T Spline 16/32 DP	1.40" (35.56)	1.75" (44.45)
16D	1" Straight Keyed	1.80" (45.72)	2.10" (53.34)
16M	1" SAE 6B Spline	1.95" (49.53)	2.30" (58.42)
16C	1" 15T Spline 16/32 DP	1.70" (43.18)	1.95" (49.53)
16P	1 1/8" Straight Keyed	1.85" (46.99)	2.15" (54.61)
16H	1 1/4" Straight Keyed	2.05" (52.07)	2.40" (60.96)
16I	1 1/4" 14T Spline 12/24 DP	2.00" (50.80)	2.32" (58.93)
151010	Required spacer for Charlynn 4000 standard motor shaft		

\* Motor Shaft Length: Distance from hydraulic motor mounting flange to tip of motor output shaft (see above).

**Heco Terms and Conditions of Sale: [www.hecogear.com/termsandconditions.pdf](http://www.hecogear.com/termsandconditions.pdf)**  
**Heco Warranty: [www.hecogear.com/warranty.pdf](http://www.hecogear.com/warranty.pdf)**