



## ANNOUNCING - DESIGN REVISION 8

- A revision to the Heco Model 16 design will take effect in December 2017. The revision will include new design taper roller output shaft bearings. This bearing change requires a new seal carrier design as well.
- The existing revision 7 seal carrier design will continue to be available in the SK16-U seal kit for the next 8-10 years. This universal seal kit is backwards compatible with all Model 16 reducers produced from 1976 through 2017.
- Revision 8 units will begin to ship in December 2017 as inventories of revision 7 housings and bearings are depleted. After that point all new Model 16 units shipped will be the revision 8 design.

### IDENTIFICATION:

- For easy visual identification and to avoid confusion, revision 8 units will receive a 5-bolt seal carrier pattern in contrast to the previously used 6-bolt pattern.
- In addition, the revision number is engraved into the mounting flange of each unit as the last digit of its model number. For example, in the model 16CF1-45-8, the 8 will denote revision 8.

Seal carrier bolt pattern difference shown in the below pictorials:

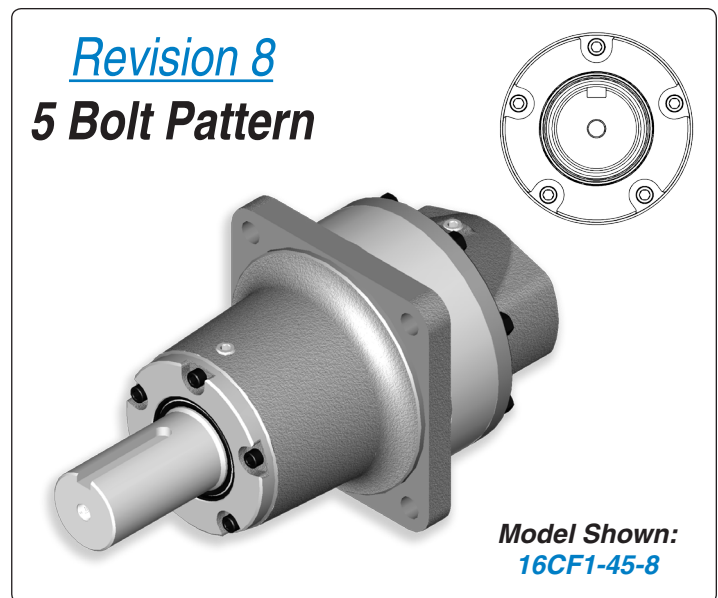
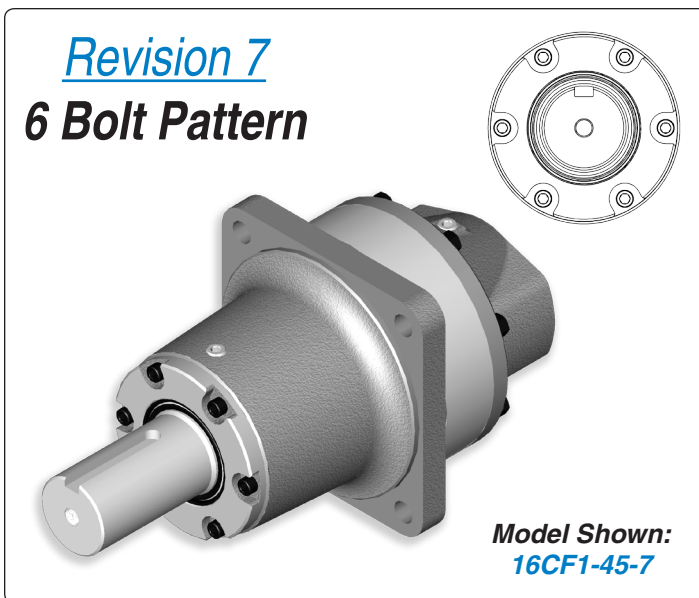

**NOTE:** The new Model 16 revision 8 seal carrier design is **NOT** compatible with the revision 7 design. This means that any current SK16-U seal kits will not fit revision 8 units. Revision 8 seal kits and seal carriers will be available in December 2017 and this design change information will be printed in the 2018 price list.